

- 1 GENERAL DESCRIPTION 1**
- 2 SYSTEM’S SPECIFICATION 2**
 - 2.1 BASIC SPECIFICATION 2
 - 2.2 SYSTEM’S GENERAL SPECIFICATION 2
 - 2.3 ELECTRICAL & OTHER SPECIFICATIONS 3
 - 2.4 SYSTEM MODULES 4
 - 2.5 SYSTEM CAPACITY CONFIGURATIONS 5
- 3 PREPARATION & NOTE FOR THE SYSTEM’S INSTALLATION 6**
 - 3.1 PREPARATION FOR SYSTEM INSTALLATION 6
 - 3.2 SPECIAL REQUIREMENTS FOR INSTALLATION ENVIRONMENT 6
 - 3.3 EQUIPMENT REMARKS 6
- 4 AV-48 PCB & CABINET LAYOUT 7**
 - 4.1 AV-48 THREE-DIMENSIONAL VIEW LAYOUT 7
 - 4.2 AV-48 BUILT-IN STANDARD RACK LAYOUT 8
 - 4.3 AV-48 INTER-CIRCUIT LAYOUT 9
 - 4.4 AV-48 SYSTEM WALL MOUNTING INSTALLATION 10
 - 4.5 AV-48 MOTHER BOARD UNIT (A10MBUA) 11
 - 4.6 AV-48 POWER UNIT (A10PWUA) 12
 - 4.7 AV-48 MAIN PROCESSING UNIT (A10MPUA) 13
 - 4.8 AV-48 TRUNK UNIT (A9TKUA) 14
 - 4.9 AV-48 CALLER ID CARD (D1CIDC) 15
 - 4.10 AV-48 KEY PHONE STATION UNIT (A10STUA) 16
 - 4.11 AV-48 SLT STATION UNIT (A10SLUA) 17
 - 4.12 AV-48 HYBRID STATION UNIT (A10HYUA) 18
 - 4.13 AV-48 VOICE SERVICE CARD (A10VSCA) 19
 - 4.14 AV-48 REMOTE PROGRAMMING CARD (A6RPCA) 20
 - 4.15 AV-48 MULTI-FUNCTION CARD (A6MFCA) 21
- 5 AV-48 SYSTEM WIRING & INSTALLATION 22**
 - 5.1 AV-48 POWER INSTALLATION : AC/DC 22
 - 5.2 AV-48 SYSTEM BACK-UP BATTERY INSTALLATION 23
 - 5.3 AV-48 CO LINE WIRING 24
 - 5.4 AV-48 POWER FAILURE TRANSFER (PFT) PHONE WIRING 25
 - 5.5 AV-48 KEY PHONE STATION WIRING 26
 - 5.6 AV-48 SINGLE LINE STATION WIRING 27
 - 5.7 AV-48 DOOR PHONE INSTALLATION 28
 - 5.8 AV-48 MULTI-FUNCTION SENSOR INSTALLATION 29

5.9	AV-48 MULTI-FUNCTION RELAY—DOOR SWITCH INSTALLATION	30
5.10	AV-48 EXTERNAL MUSIC SOURCE INSTALLATION	31
5.11	AV-48 EXTERNAL PAGING INSTALLATION	32
5.12	AV-48 RS232 (SMDR) INSTALLATION	33

1 General Description

Thanks for choosing our **AV-48** key telephone system.

AV-48 possesses the most advanced technology with 6 free I/O interface slots, provides maximum 48 ports. Trunk Unit each has 4 CO ports, while Station Unit each has 8 extension ports. Also every system can be installed with one piece of hybrid, whose all 8 ports were designed as hybrid ports and can be connected directly with the key phone or SLT. According to customers' requirements, you can choose KP station unit, SLT unit or hybrid unit optionally. The Caller ID function is supported not only to the key phone but also the SLT for all incoming calls and the transferred calls.

AV-48 is equipped with many peripherals, such as RS-232 for data output, door phone, multi-function sensor, multi-function relay, remote programming maintenance, external music source, external paging, voice auto-attendant and so forth. We are proud to say, this system is a break-through product among the key telephone systems.

AV-48 KTS is of a cards insertion designs. The ports of Mother Board, Power Unit, Trunk/station Unit and peripherals act independently. All system's ports use RJ45 Module Connector Wiring disregarding the traditional wiring method. This change makes the construction more efficiently and reliably. All functions of this system can be programmed to realize "One-Touch" action.

This installation manual presents the clear descriptions of all the steps of installation and the notices. We hope to assist you to complete the system installation successfully and obtain the telecommunication service, efficient management to the utmost extent.

If there is any query in this field, please feel free to contact the nearest authorized agent for assistance.

2 System's Specification

2.1 Basic Specification

- System Capacity : 48 free ports
 CO lines: 0~8
 Station lines: 0~48
- System dimensions : 440mm × 305.6mm × 202mm
- System Control : Stored Program Control
- Switch Control : Space Division Matrix
- Maximum Power Consumption : 65W
- Working Temperature : 0°C~45°C
- Working Humidity : 10% ~90% (non-condensing)

2.2 System's General Specification

The trunk cards and station units should be installed at any 6 free I/O interface slots.
 All the peripherals cards should be installed at the specified sockets.

AV-48		Basic Capacity	Expansion Capacity	Maximum Capacity
Co Line		0	4	8
Extension	Key Phone	0/0	8/0	48/0
	SLT	0/0	0/8	0/48
Door Phone		0	2	2
Relay Switches		0	2	2
Sensor Interfaces		0	2	2
Auto Attendant		0	1/2	1/2
RS232 for SMDR		1	0	1
UPS Interface		1	0	1
Speed Dial		1000	0	1000
Power Failure Transfer Phone (PFT)		0	4	8

Table 1 System's General Specification

2.3 Electrical & Other Specifications

AV-series		AV-48
Input AC Voltage		AC220V/110V (±15%) 50/60hz
Power Consumption	System	65W
	Key Telephone	1~2W
	SLT	0.85W
	Door Phone	0.5W
System Power Back-up Battery 7AH		1~2 hours
Dialing Signal	Outgoing Dialing	Tone / Pulse
	Intercom Dialing	Tone / Pulse / Digital
Loop Resistance	Co Line	Maximum: 1.5K Ω
	Key Telephone	Maximum: 40 Ω
	SLT	Maximum: 400 Ω
	Door Phone	Maximum: 40 Ω
	External Paging	Maximum: 800 Ω
Wiring Installation	Co Line	2-conductor wiring
	Key Phone	4-conductor wiring
	SLT	2-conductor wiring
	Door Phone	2-conductor wiring
	External Paging	2-conductor wiring
	External Music Source	2-conductor wiring
	Relay	2-conductor wiring
	Sensor	2-conductor wiring
	Fax	2-conductor wiring
	SMDR	D-TYPE 9 pins
Relay	Type	SPDT (just 1 set is enough)
	Power Capacity	Maximum 120V×7A
	Function	Supported by system software: Door Switch, External Paging, Account Code, Adjustable Ringing Volume...
System Dimension (mm)		440mm×305.6mm×202mm
Key Phone Dimension (mm)		200 * 180 * 75mm
Working Temperature		0°C ~ 45°C
Working Humidity		10%~90% (non-condensing)
Switch Mode		SDM (Space Division Matrix)
Control Mode		Stored Program Control (SPC)

Table 2 Electric standard for System

- Subject to the changes without notice.
- The correct specification to be mentioned on the quotation or contract.

2.4 System Modules

Model No.	Description	Remark
A10-48A	MAIN EQUIPMENT , consisting of (A10CBMA + A10MPUA)	Standard Shipment
A10CBMA	MAIN CABINET , consisting of (Plastic Cabinet + A10MBUA + A10PWUA)	Spare Part
A10PWUA	SWITCHING POWER SUPPLY UNIT	Spare Part
A10MBUA	MOTHER BOARD UNIT , consisting of 12 I/O slots.	Spare Part
A10MPUA	MAIN PROCESSING UNIT , consisting of RS-232 interface	Spare Part
A9TKUA	TRUNK UNIT , consisting of 4 CO Line Ports, with Lightning Protection; Share with AV-96	Expansion Card
D1CIDC	FSK/DTMF CLI INTERFACE , one Channel of POTS Caller Number Identification card.	Optional Card
A10STUA	KEY STATION UNIT , consisting of 8 Key Station Ports	Expansion Card
A10HYUA	HYBRID STATION UNIT , consisting of 8 Fully Hybrid Station Ports (maximum one card in the system)	Expansion Card
A10SLUA	SINGLE LINE STATION UNIT , consisting of 8 Single Line Station Ports	Expansion Card
A9VSCA	VOICE SERVICE UNIT , consisting of 2 Voice Channels (60 seconds per channel); Share with AV-96	Optional Card
A6MFCA	MULTI FUNCTION CARD , consisting of (2 Sensors + 2 Relays + 2 Door Phone Interfaces)	Optional Card
A6MDCA	METERING DETECTION CARD (for both 12KHz and 16KHz Metering Pulse)	Optional Card
A6RPCA	REMOTE PROGRAMMING CARD (standard Modem design)	Optional Card

Table 3 System's Accessories

- Subject to the changes without notice.
- The correct specification to be mentioned on the quotation or contract.

2.5 System Capacity Configurations

System capacity	Station Unit Quantity (Key Phone /SLT/Hybrid Station Unit; but only one pieces of Hybrid Station can be installed.)					
	1	2	3	4	5	6
Trunk Unit Qty.	0	0	0	0	0	0
0	008	016	024	032	040	048
1	408	416	424	432	440	
2	808	816	824	832		

Table 4 System Capacity Configurations

- This system provides 6 free I/O interface slots. Any Trunk Units or Station Units can be installed to these 6 slots according to user’s requirements.
- Three different Station Units (Key phone station unit, SLT station unit or Hybrid station unit) are at user’s option. But only one piece of Hybrid station unit can be installed.

3 Preparation & Note for the System's Installation

3.1 Preparation for System Installation

- Please check whether the system capacity and the quantity of phones are suitable or not.
- Please prepare the necessary wires and instruments for installation.
- Please carefully read this manual before installation and follow up the procedures of installation on this manual.

3.2 Special Requirements for Installation Environment

- Input AC Voltage: AC220V/110V (±15%) 50/60hz
- Back-up Battery: Built-in charger included. Connect directly to DC24V battery for power-off.
- Wiring Requirements :
 - ◇ CO Line: 2-conductor wiring
 - ◇ Key Phone: 4-conductor wiring
 - ◇ SLT : 2-conductor wiring
 - ◇ Door Phone: 2-conductor wiring
 - ◇ Relay / Sensor: 2-conductor wiring
 - ◇ External Music Source / External Paging: 2-conductor wiring

3.3 Equipment Remarks

- The system should be installed at a clean, dry and secure position, 10 centimeters above the ground to avoid the vibration.
- The location must have adequate ventilation and a temperature range between 0 ~ 45° C with a 10 ~ 90% non-condensing relative humidity.
- The installation site should have sufficient room to mount the KSU along with the necessary connecting blocks and ancillary equipment. The installation site should not be at the area with static electricity (e.g. Dry copiers), or vibration (e.g. Heavy duty machinery).
- This system must use the independent power input. The power should better not share with other power-consumption equipment, for example: huge power consumption machine and be controlled directly by main switch. In addition, the location must be far away from high frequency & noise soundings to avoid the interference from radiation 『EMI』 .
- The power must use three-way socket (with grounding connector).
- Voltage Stabilizer is recommended if the electricity supply is not so stable.
- Please use the lightning-protection equipment to guarantee system's stability.
- Suggest using twist wires for CO line & station line to avoid noise and interruption.
- SLT wiring must be away from some other disturbance (e.g.: radio wave).
Otherwise a separate earth is required in addition to the third earth wire on the AC circuit. Otherwise a separate earth is required in addition to the third earth wire on the AC circuit.

4 AV-48 PCB & Cabinet Layout

4.1 AV-48 Three-dimensional View Layout

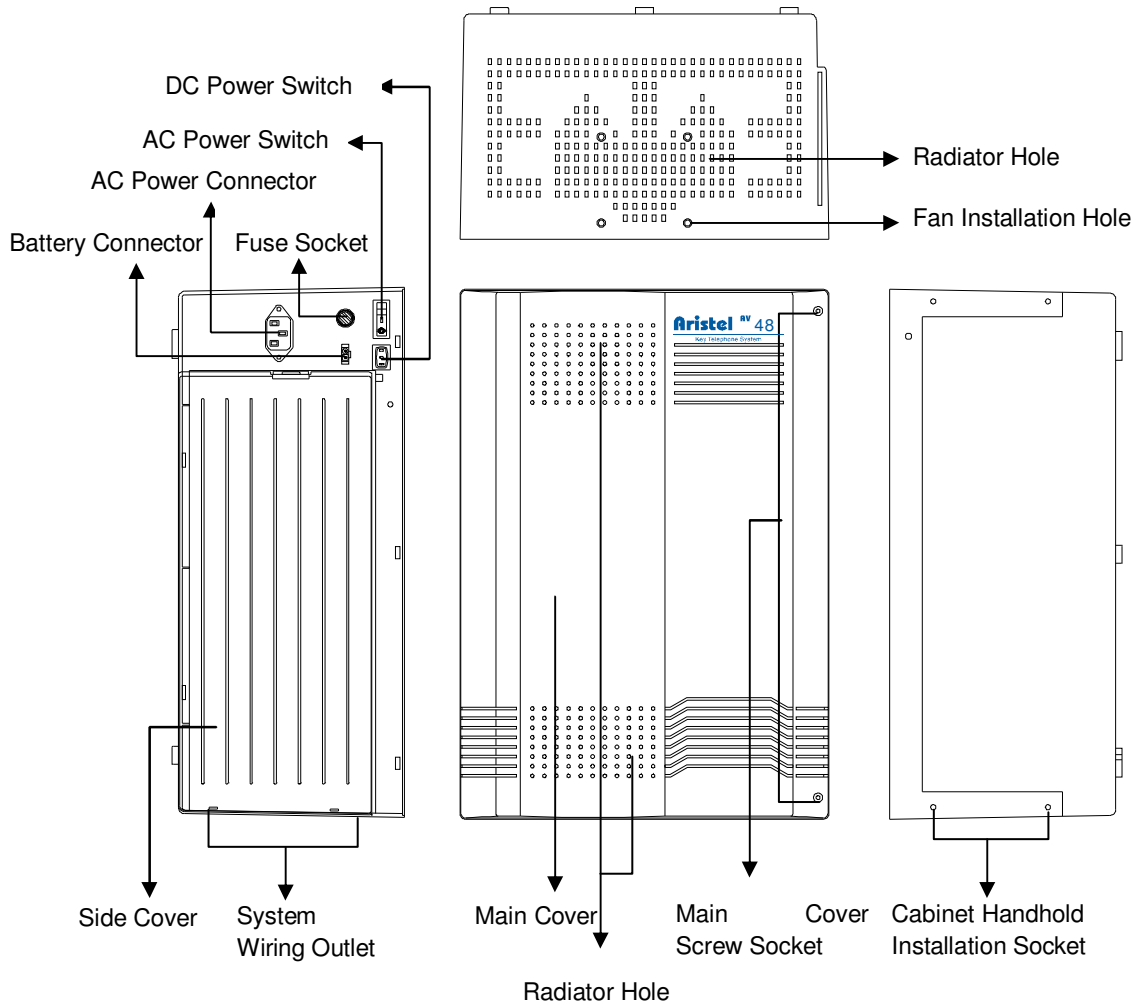

Chart 1: AV-48 Three-dimensional View Layout

- System dimensions (mm) : 440mm × 305.6mm × 202mm

4.2 AV-48 Built-in Standard Rack Layout

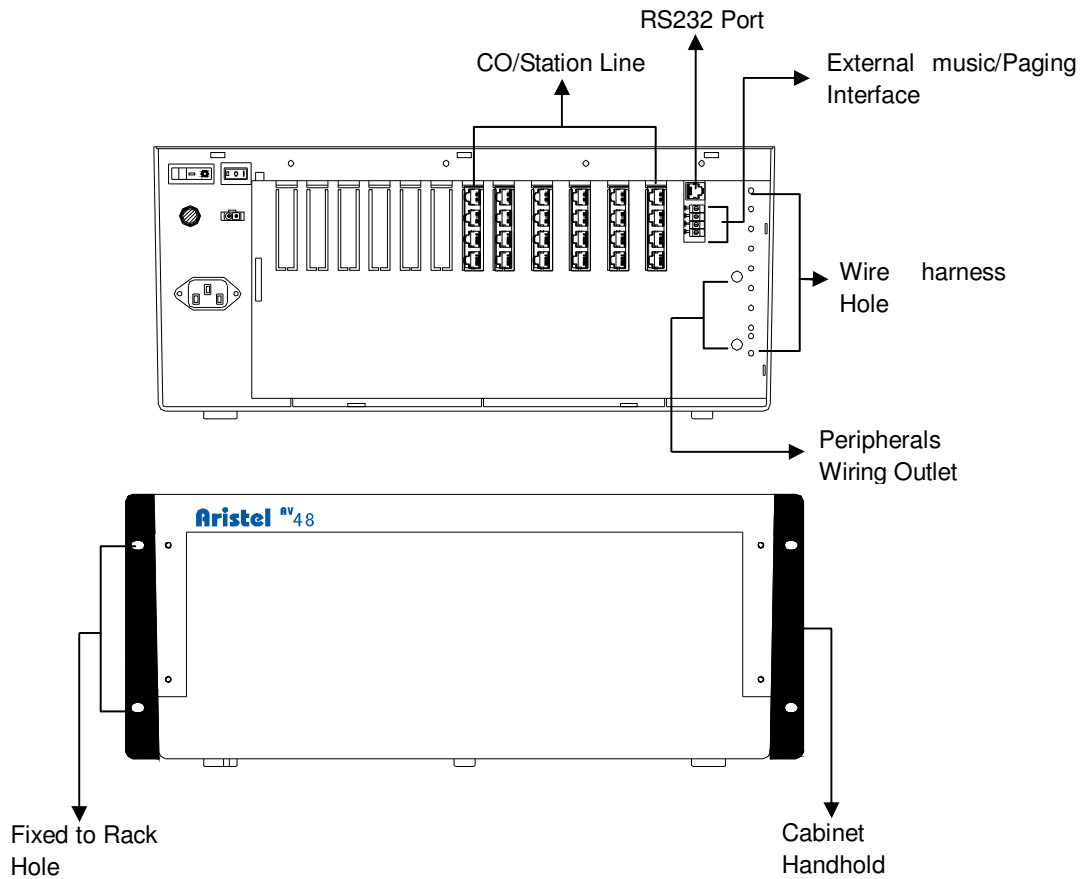

Chart 2: AV-48 built-in Standard Rack Layout

4.3 AV-48 Inter-Circuit Layout

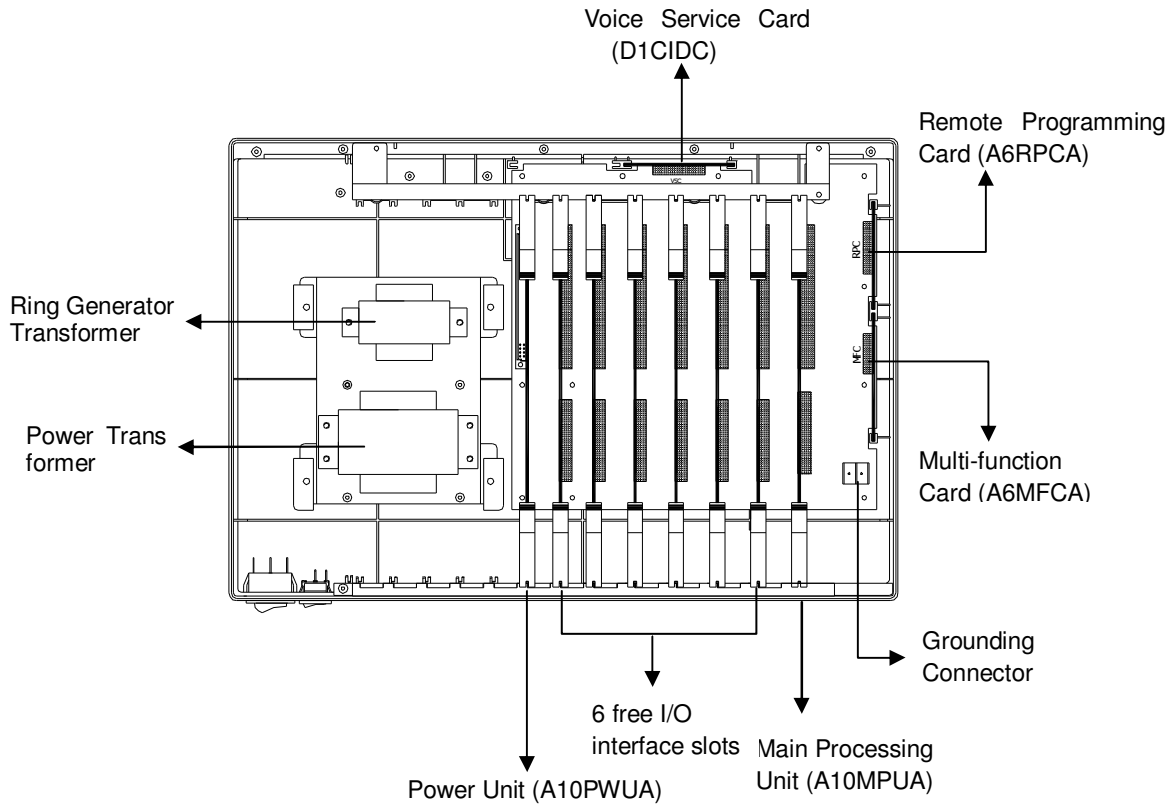
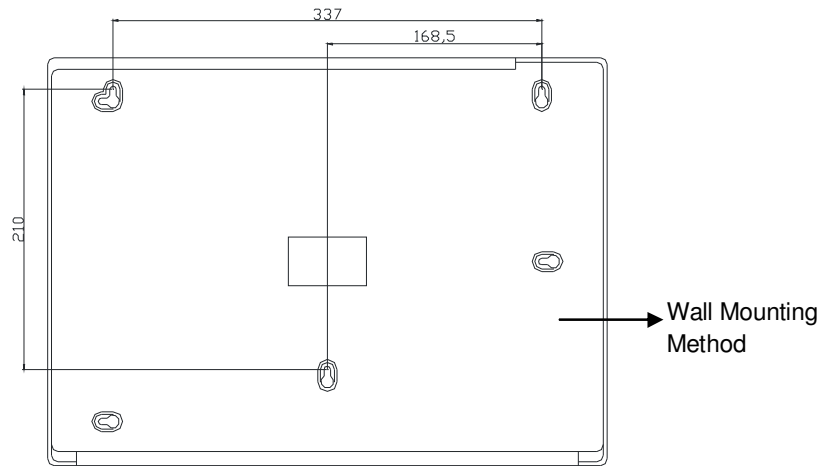

Chart 3: AV-48 Inter-circuit Layout

- AV-48 Maximum Capacity: 48 Ports/6 free I/O interface slots
- CO Line Max. Capacity: 8 Ports
- Station Line Max. Capacity: 48 Ports (Key phone, SLT Station or Hybrid Station unit. But only one pieces of Hybrid station unit can be installed in one system)
- Auto Attendant, Maximum 2 channels (60seconds)

Note: Please fasten the snap-close after fitting well all I/O Units in the correct slots.

4.4 AV-48 System Wall Mounting Installation



Hanging measure scale

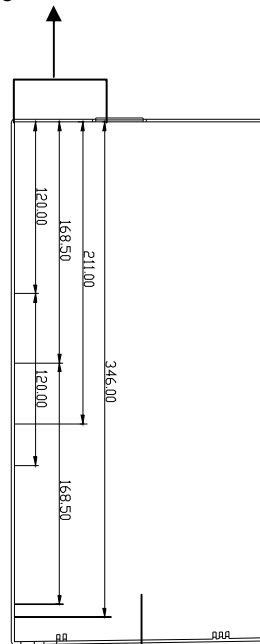

Side Cover
inside View

Chart 4: AV-48 System Wall Mounting Installation

- System suggested being installed 10cm or more above ground, avoiding humidity.
- There are the two-way hanging measure scales on the inside-surface of System Side Cover, which is convenient for customer's installation.

4.5 AV-48 Mother Board Unit (A10MBUA)

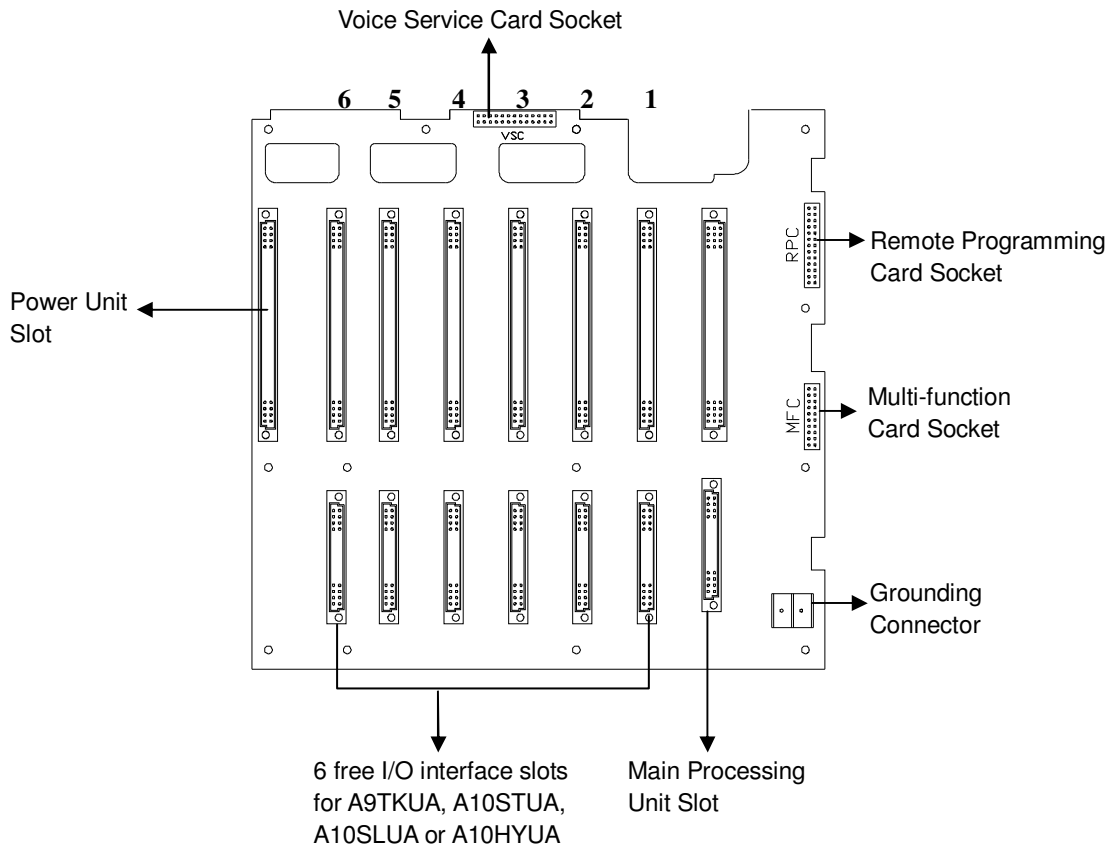

Chart 5: AV-48 Mother Board Unit (A10MBUA)

- A10MPUA and A10PWUA should be installed at the specified slots.
- The Station cards (A10STUA, A10HYUA or A10SLUA) can be installed at any 6 free I/O interface slots on A10MBUA. IO1~IO6: 6 free I/O interface slots for A9TKUA, A10STUA, A2SLUA or A10HYUA. Only one piece of A10HYUA can be used.
- Three peripheral cards (1 A9VSCA, 1 A6RPCA and 1 A6MFCA) should be installed at the designed slots.
- A10MBUA is directly mounted on the System's Plastic cabinet.

4.6 AV-48 Power Unit (A10PWUA)

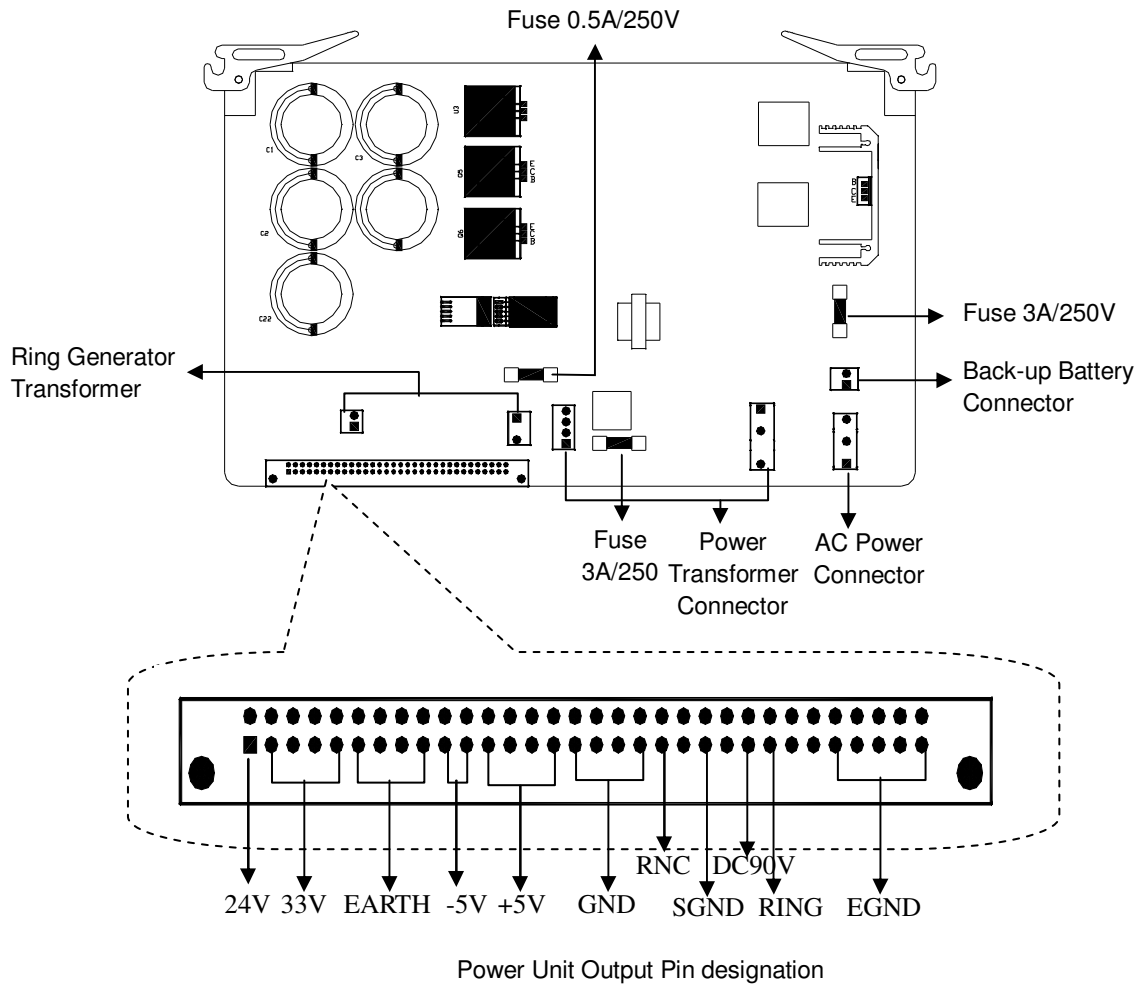

Chart 6: AV-48 Power Unit (A10PWUA)

4.7 AV-48 Main Processing Unit (A10MPUA)

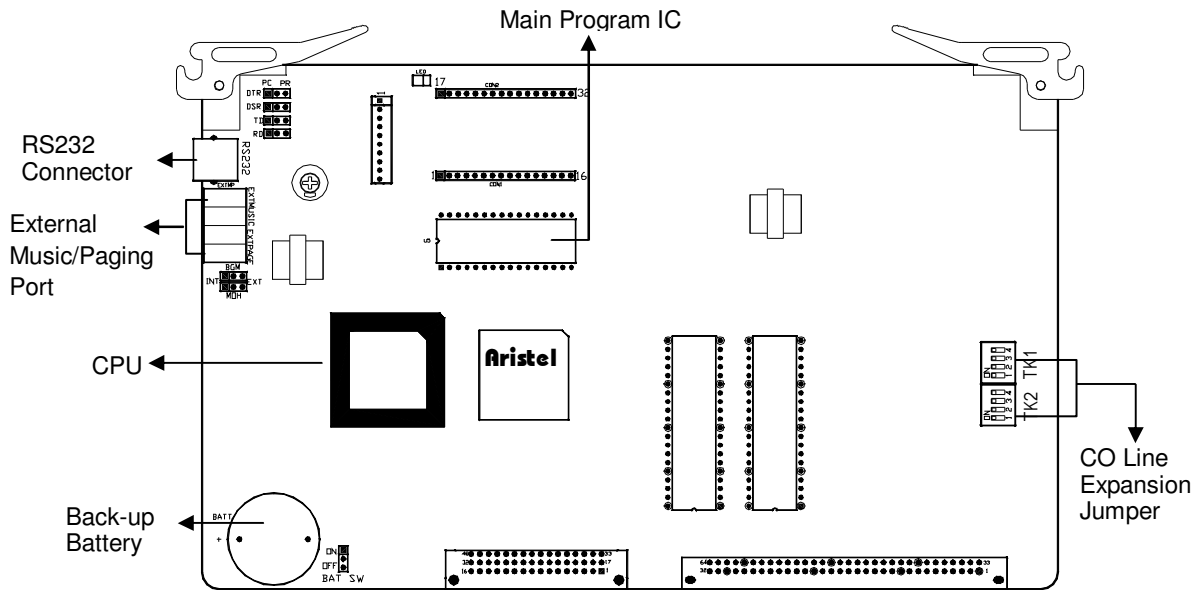

Chart 7: AV-48 Main Processing Unit (A10MPUA)

- A10MPUA should be inserted in the first Slot on A10MBUA.
- System Main Program IC is inserted on A10MPUA.
- There are standard RS232, external music source and external paging ports on A10MPUA.
- When adding Trunk Units to the system, the CO Line Expansion Jumper on A10MPUA should be corresponding with the Jumper to select Trunk Unit Position on A9TKUA (See Table 6).

Trunk Unit Slot	CO Line Expansion Jumper (0: OFF; 1: ON)	
	TK1	TK2
1	0000	1111
1、2	0000	0000

Table 5: CO Line Expansion Jumper on A10MPUA

4.8 AV-48 Trunk Unit (A9TKUA)

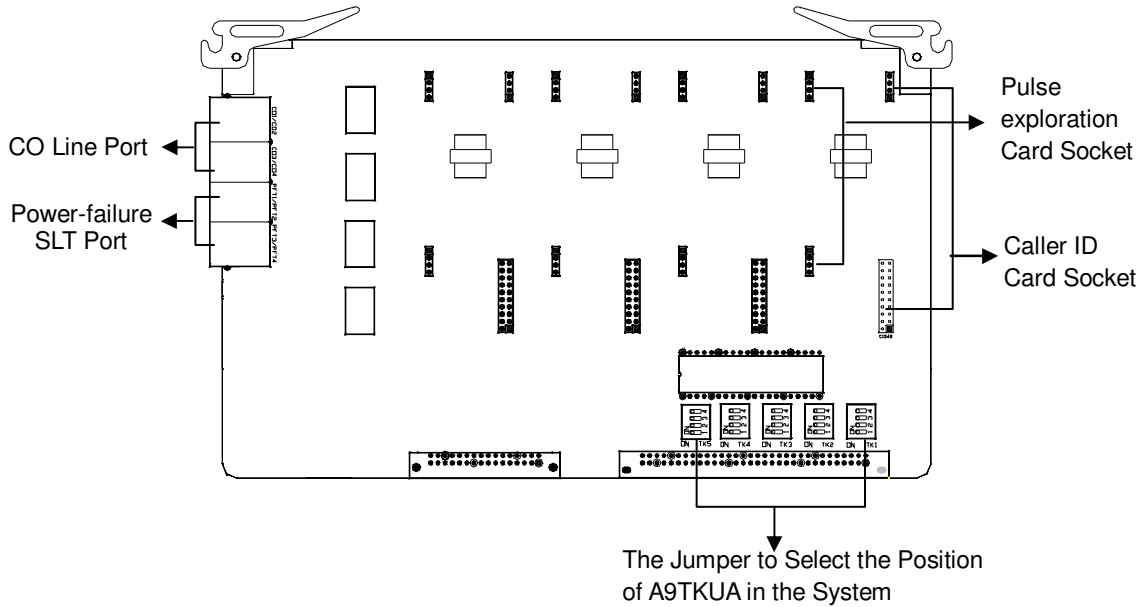

Chart 8: AV-48 Trunk Unit (A9TKUA)

- A9TKUA, sharer with AV-96, should be installed at any free slot from IO1 to IO2 on A10MBUA in sequence.
- The jumper to select the position of A9TKUA in the system should be corresponding with the CO Line Expansion Jumper (See Table 5) on A10MPUA.

Trunk Unit Position	The Jumper to select Trunk Unit Position (0: OFF; 1: ON)				
	TK1	TK2	TK3	TK4	TK5
I01	1111	0000	0000	0000	0000
I02	0000	1111	0000	0000	0000

Table 6: Trunk Unit Position Selection Jumper on A9TKUA

4.9 AV-48 Caller ID Card (D1C1DC)

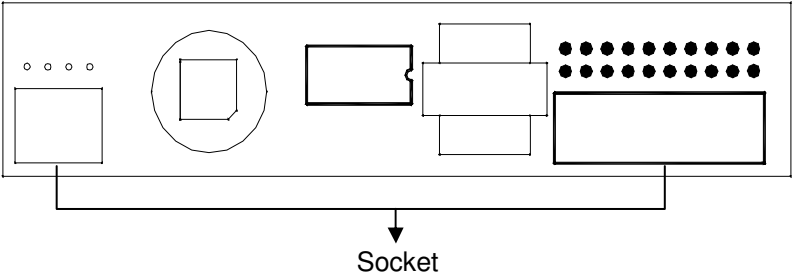

Chart 9: AV-48 Caller ID Card (D1C1DC)

- Each A10CIDA can be added to one A9TKUA CO Line.
- Caller ID function as well as incoming call forward can be supported not only key phone but also SLT (with DTMF signal) phone.

4.10 AV-48 Key Phone Station Unit (A10STUA)

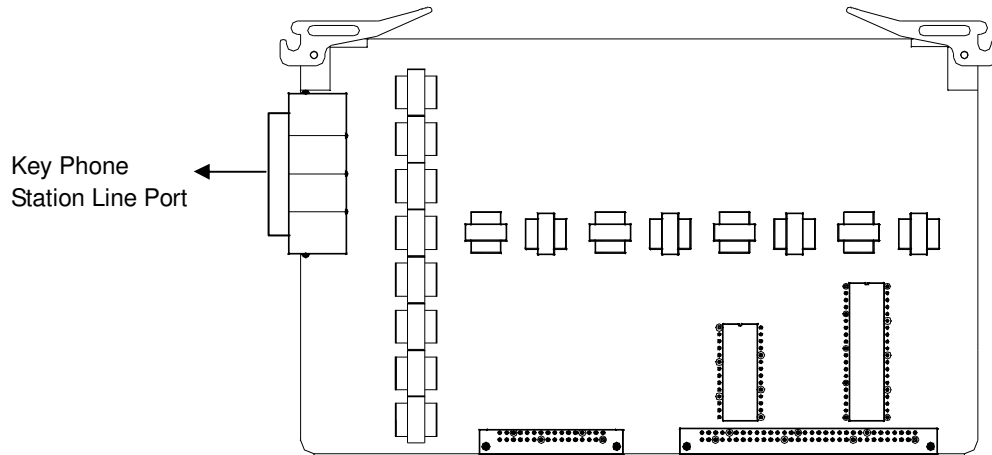

Chart 10: AV-48 Key Phone Station Unit (A10STUA)

- A10STUA can be installed at any free slots from IO1 to IO6 on A10MBUA.
- Each A10STUA contains 8 Key Phone station ports.
- All the station ports have short-circuited protector.

4.11 AV-48 SLT Station Unit (A10SLUA)

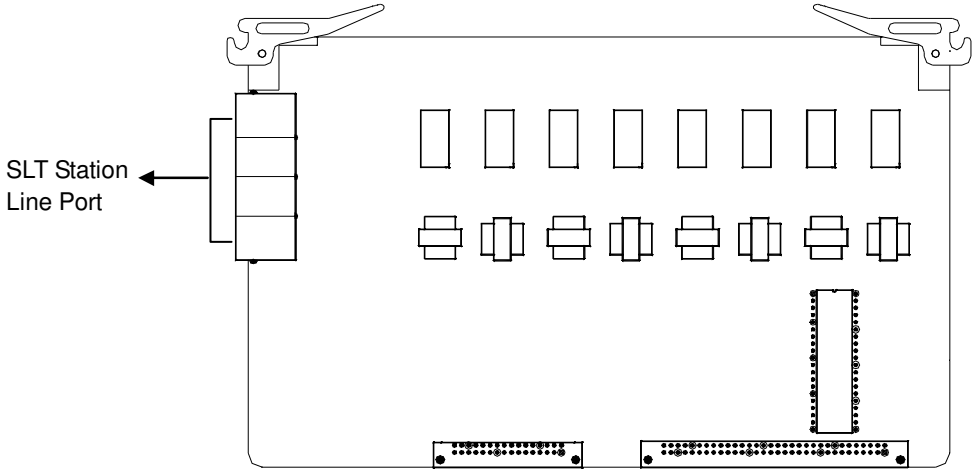

Chart 11: AV-48 SLT Station Unit (A10SLUA)

- A10SLUA can be installed at any free slot from IO1 to IO6 on A10MBUA.
- Each A10SLUA contains 8 Standard SLT station ports.
- All the station ports have short-circuited protector.

4.12 AV-48 Hybrid Station Unit (A10HYUA)

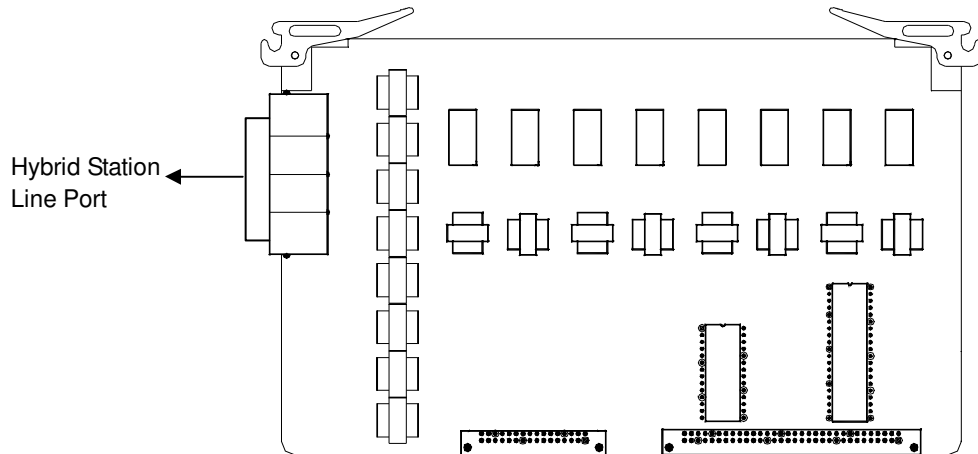

Chart12: AV-48 Hybrid Station Unit (A10HYUA)

- A10HYUA can be installed at any free slot from IO1 to IO6 on A8MBUA.
- Each A10HYUA contains 8 station line ports, which was designed as hybrid ports for key phone or SLT.
- All the station ports have short-circuited protector.

4.13 AV-48 Voice Service Card (A10VSCA)

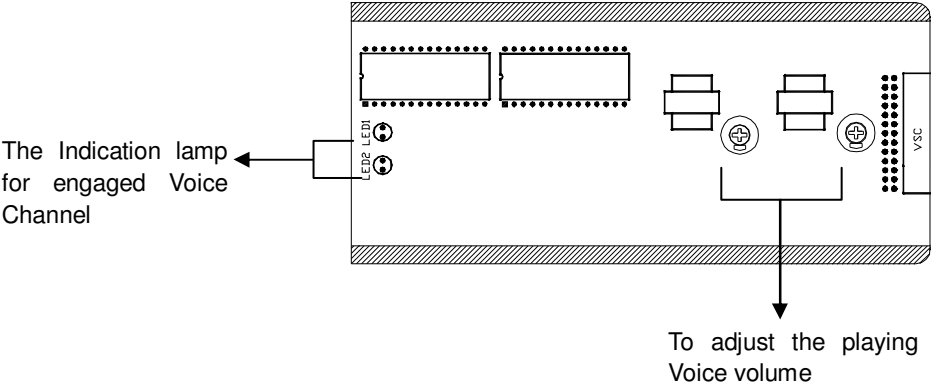

Chart 13: AV-48 Voice Service Card (A9VSCA)

- 1 piece of Voice Service Card (A9VSCA) can be installed on the system. Each A9VSCA has 2 voice channels. Total 2 channels are usable.
- A9VSCA should be installed at the designed socket on system's mother board.

4.14 AV-48 Remote Programming Card (A6RPCA)

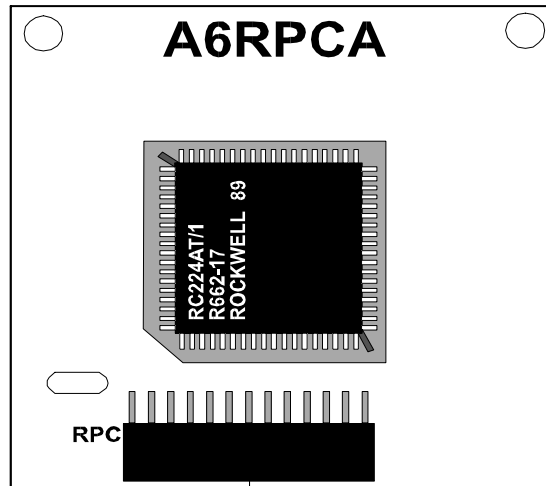

Chart 14: AV-48 Remote Programming Card (A6RPCA)

- The system offers the function of Remote Programming maintenance.
- After installing A6RPCA in this system with PC and SM (system's expert management program), the Remote Programming function will be workable.

4.15 AV-48 Multi-function Card (A6MFCA)

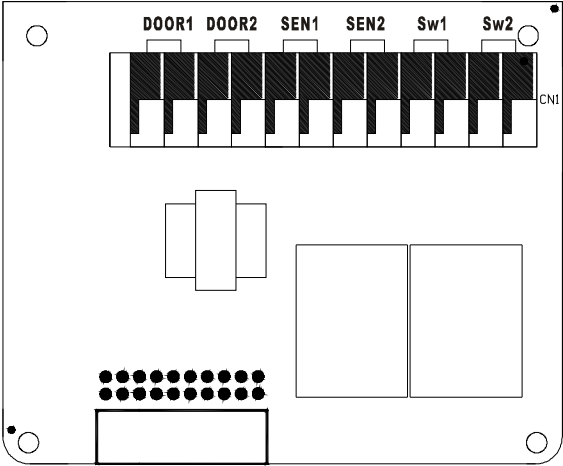

Chart14: AV-48 Multi-function Card (A6MFCA)

- Multi-function card (A6MFCA) provides 2 Door phone, 2 Relay and 2 Sensor interfaces.
- The application of multi-function sensor or relay needs the proper system software upon request.

5 AV-48 System Wiring & Installation

5.1 AV-48 Power Installation: AC/DC

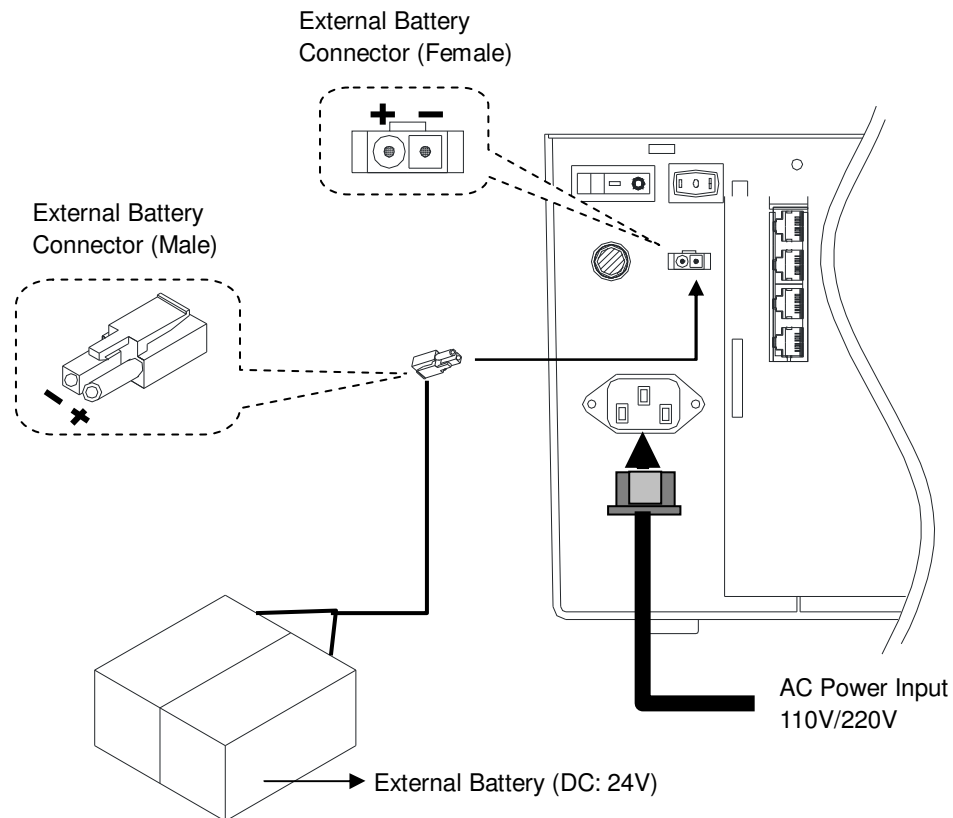

Chart 16: AV-48 Power Installation: AC/DC

- System Input AC Voltage: AC110V/220V
- Back-up Battery: 24VDC
- System Maximum Power Consumption: 65W
- Working Temperature: 0°C~45°C
- Working Humidity: 10%~90% (non-condensing)

5.2 AV-48 System Back-up Battery Installation

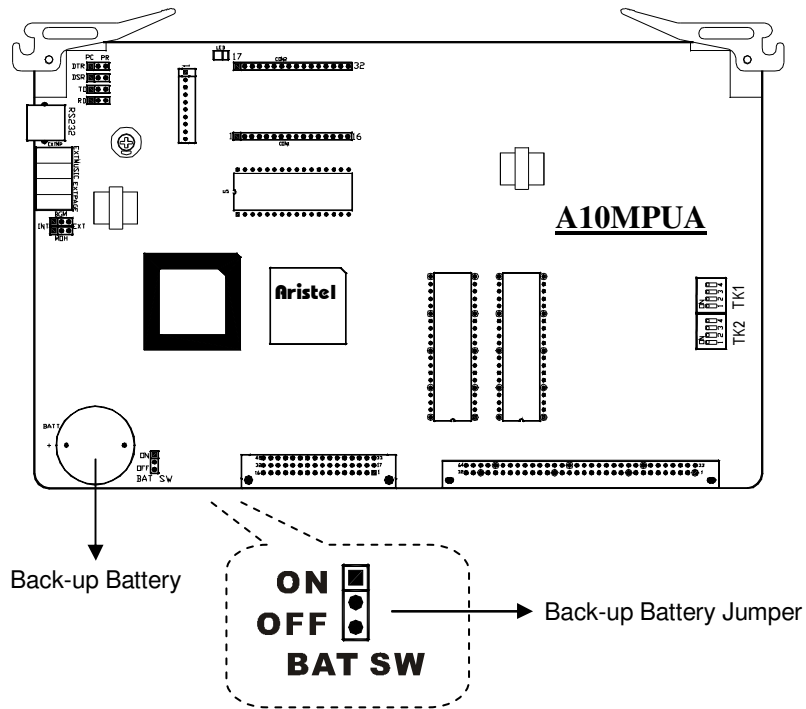

Chart 17: AV-48 Back-up Battery Activation Installation

- Back-up Battery Jumper is jumped to "OFF" when ex-factory.
- Before start-up the system, Back-up Battery Jumper should be jumped to "ON", so as to protect the programmed information from losing when power failure.
- If the system left unused for a long time, Back-up Battery Jumper should to be jumped to "OFF", or the replacement of a battery is required when start-up system again.

5.3 AV-48 CO Line Wiring

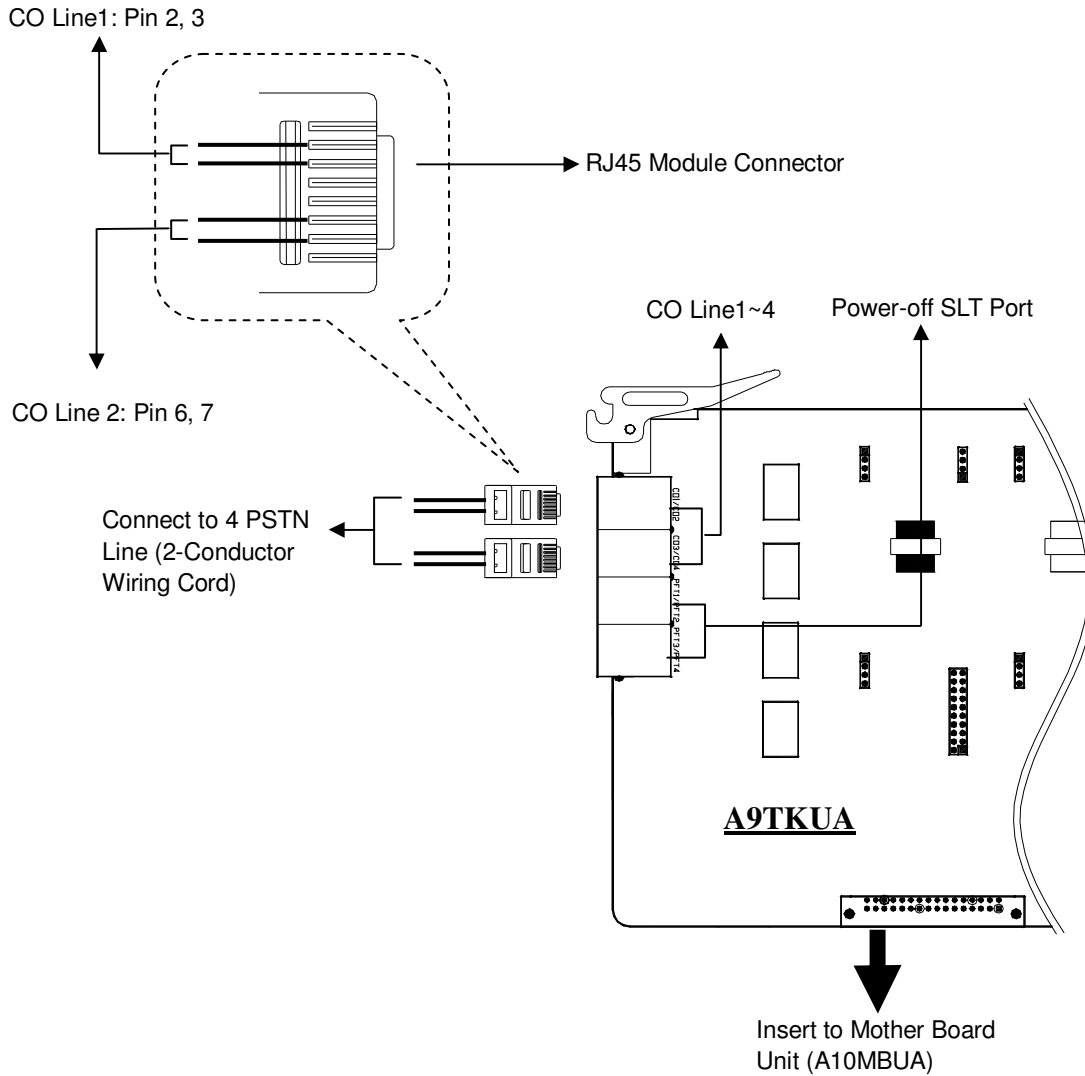

Chart 18: AV-48 CO Line Wiring

- Each Trunk Unit (A9TKUA) contains 4 CO line ports.
- Maximum 2 pieces of A9TKUA (8 ports CO lines) can be installed.
- A9TKUA is equipped with RJ45 module connector.

5.4 AV-48 Power Failure Transfer (PFT) Phone Wiring

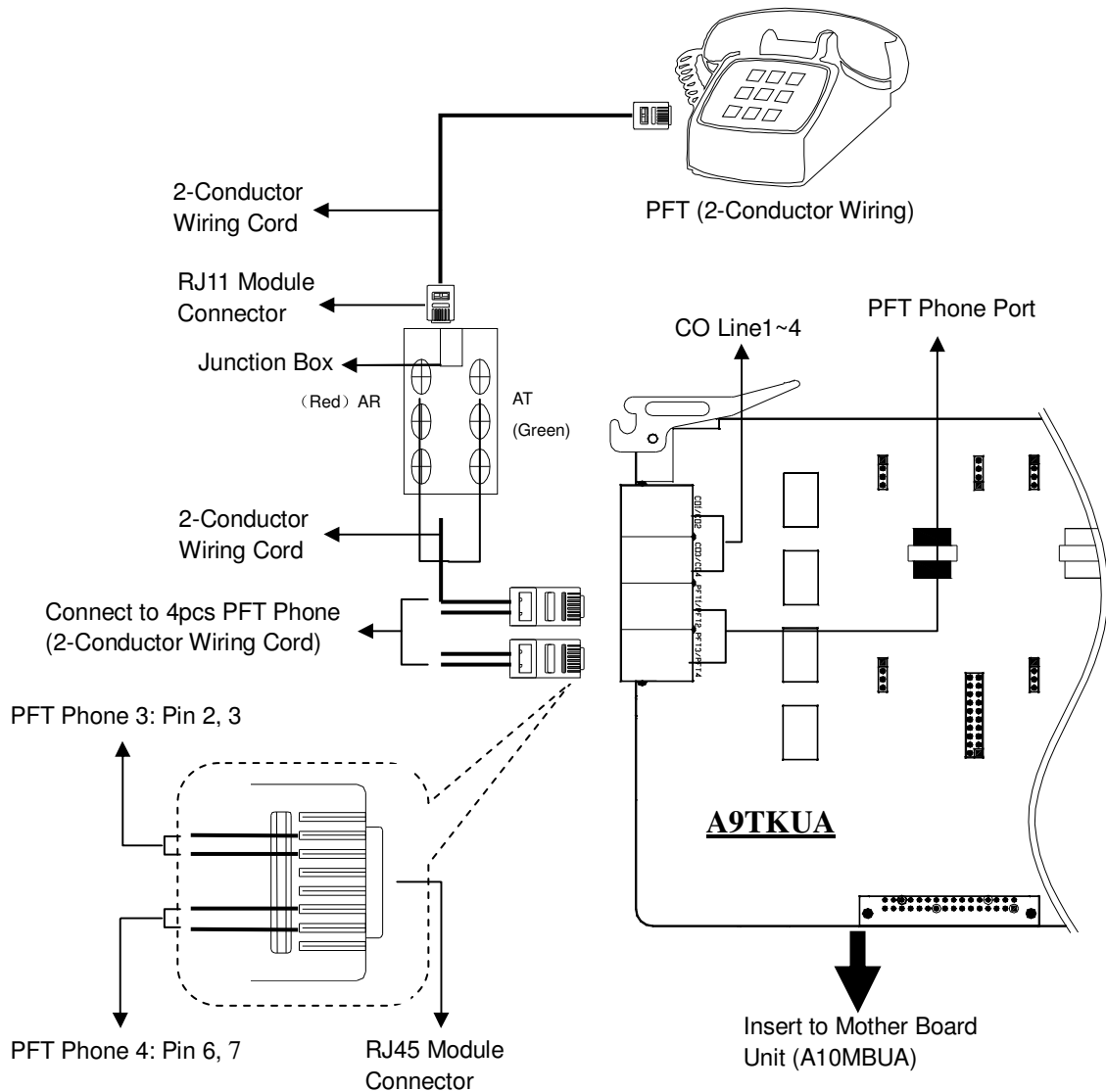

Chart 19: AV-48 Power Failure Transfer (PFT) Phone Wiring

- Each CO Line each has an in-bridge port; the connector of the in-bridge port is same with SLT port. When power fails, please pull out the RJ45 connector on A10SLUA and insert into the Power Failure Transfer Phone port on A9TKUA, so as to normally use the CO Line.
- The Qty of Power Failure Transfer Phone due to the Qty of CO Line being used.

5.5 AV-48 Key Phone Station Wiring

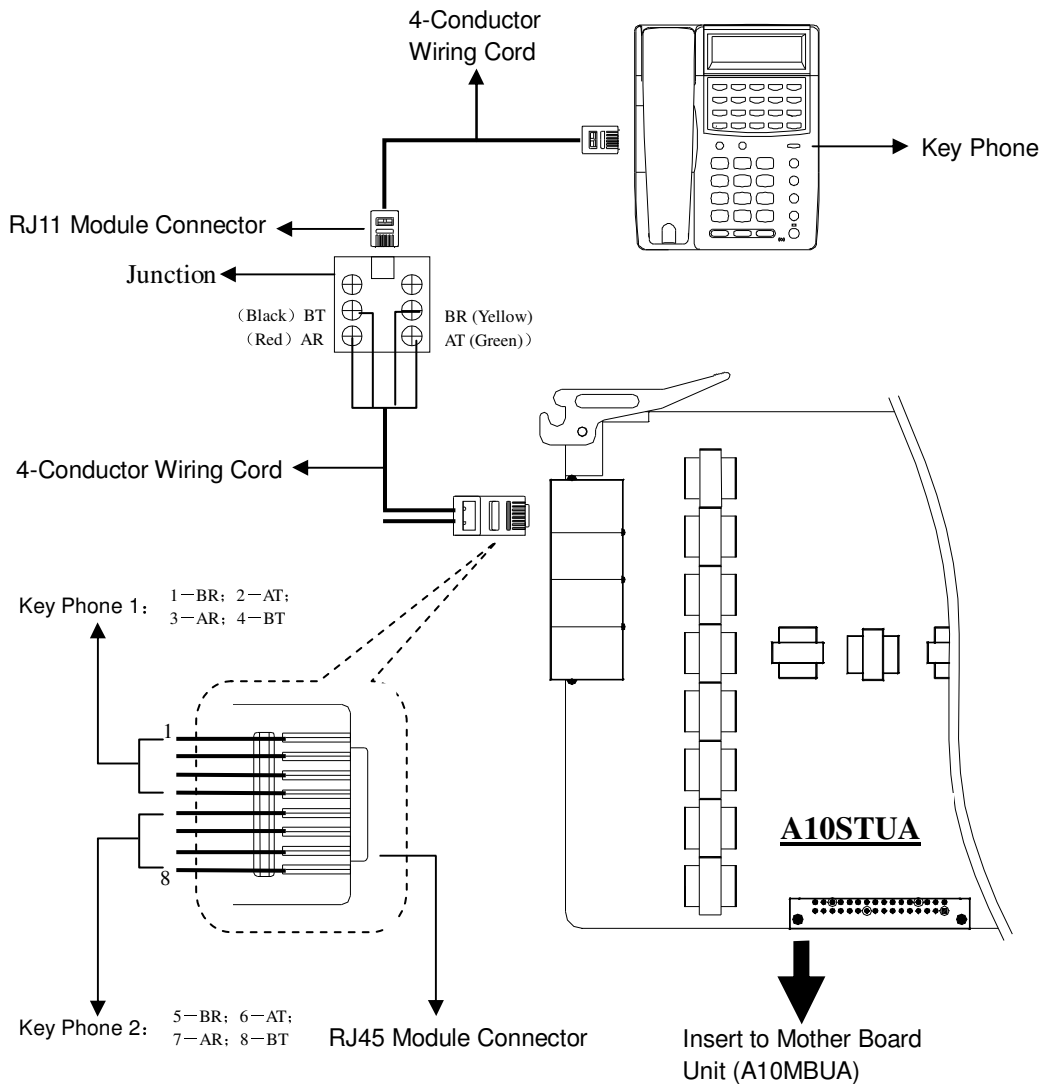

Chart 20: AV-48 Key Phone Station Wiring

- Each Key Station Unit (A10STUA) contains 8 key phone ports. Every RJ45 can be connected to 2 pieces of key phone.
- There are maximum 6 pieces of A10STUA (96 ports key phone) can be installed in the system.
- All the station ports have short-circuited protector.
- 4-conductor wiring cord is used for key phone wiring (AR/ AT, Voice) (BR/BT Power + Communication).
- A, AR/ AT: Voice Line (Red/Green, non-polarity). B, BR/BT: Power + Information (BR Yellow: anode, BT Black: cathode)

Note: Key Phone installed on A10HYUA is similar to A10STUA (as above chart 20).

5.6 AV-48 Single Line Station Wiring

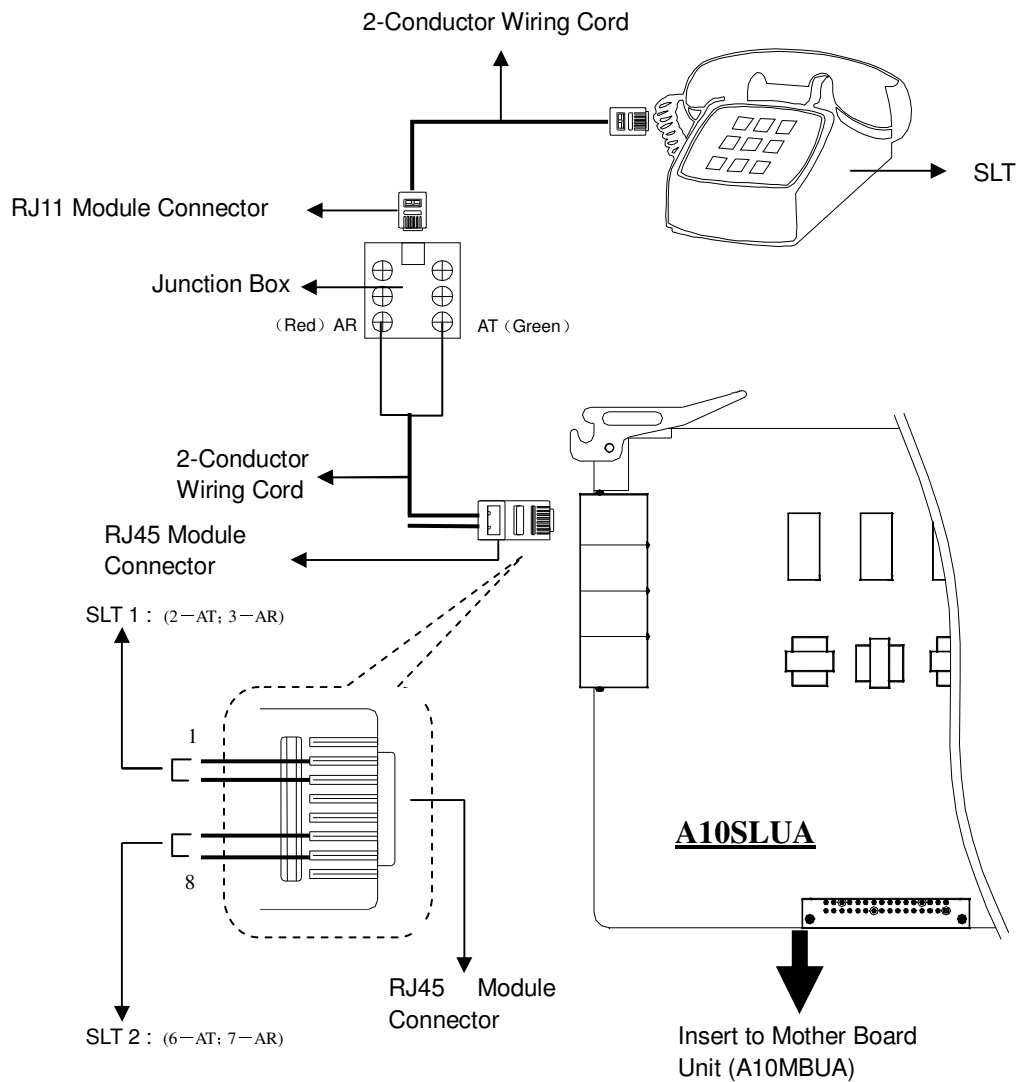

Chart 21: AV-48 Single Line Station Wiring

- Each Single Line Station Unit (A10SLUA) contains 8 SLT ports. Every RJ45 can be connected 2 pieces of SLT.
- There are maximum 6 pieces of A10SLUA (48 ports SLT) can be installed in the system.
- All the station ports have short-circuited protector.
- 2-conductor wiring cord is used for SLT wiring (AR/ AT, Voice + Power + Communication).
- AR/ AT (Red/Green, non-polarity).

Note: SLT installed on A10HYUA is similar to A10SLUA (as above chart 20).

5.7 AV-48 Door Phone Installation

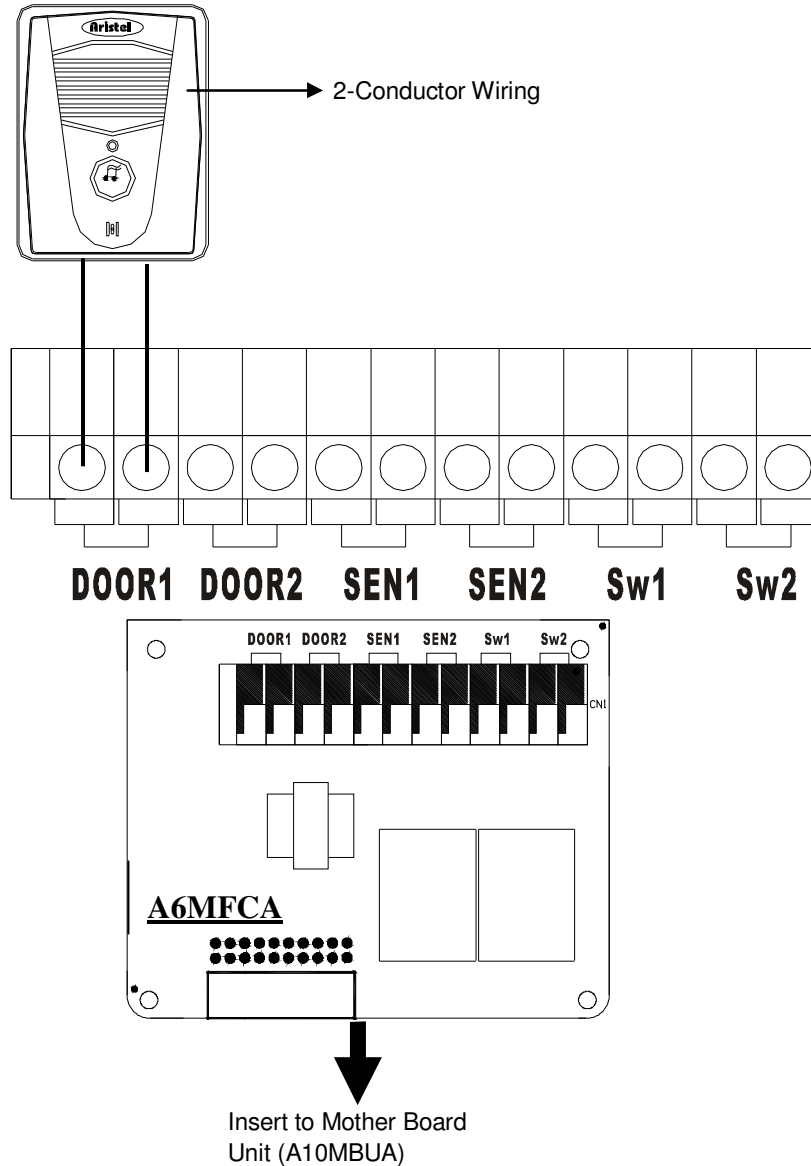

Chart 22: AV-48 Door Phone Installation

- (DOOR1, DOOR2) ports are located on A6MFCA (Standard 2-conductor wiring door phone, with non-polarity).
- The system offers two door phone installation interfaces (DOOR1, DOOR2).
- Also refer to the System Programming Zone 602.

5.8 AV-48 Multi-function Sensor Installation



图 23: AV-48 Multi-function Sensor Installation

- (SEN1, SEN2) ports locate on A6MFCA (Standard 2-conductor wiring, with non-polarity).
- The system offers two multi-function sensor installation interfaces (SEN1, SEN2).
- Also refer to the System Program Zone 303.

5.9 AV-48 Multi-function Relay—Door Switch Installation

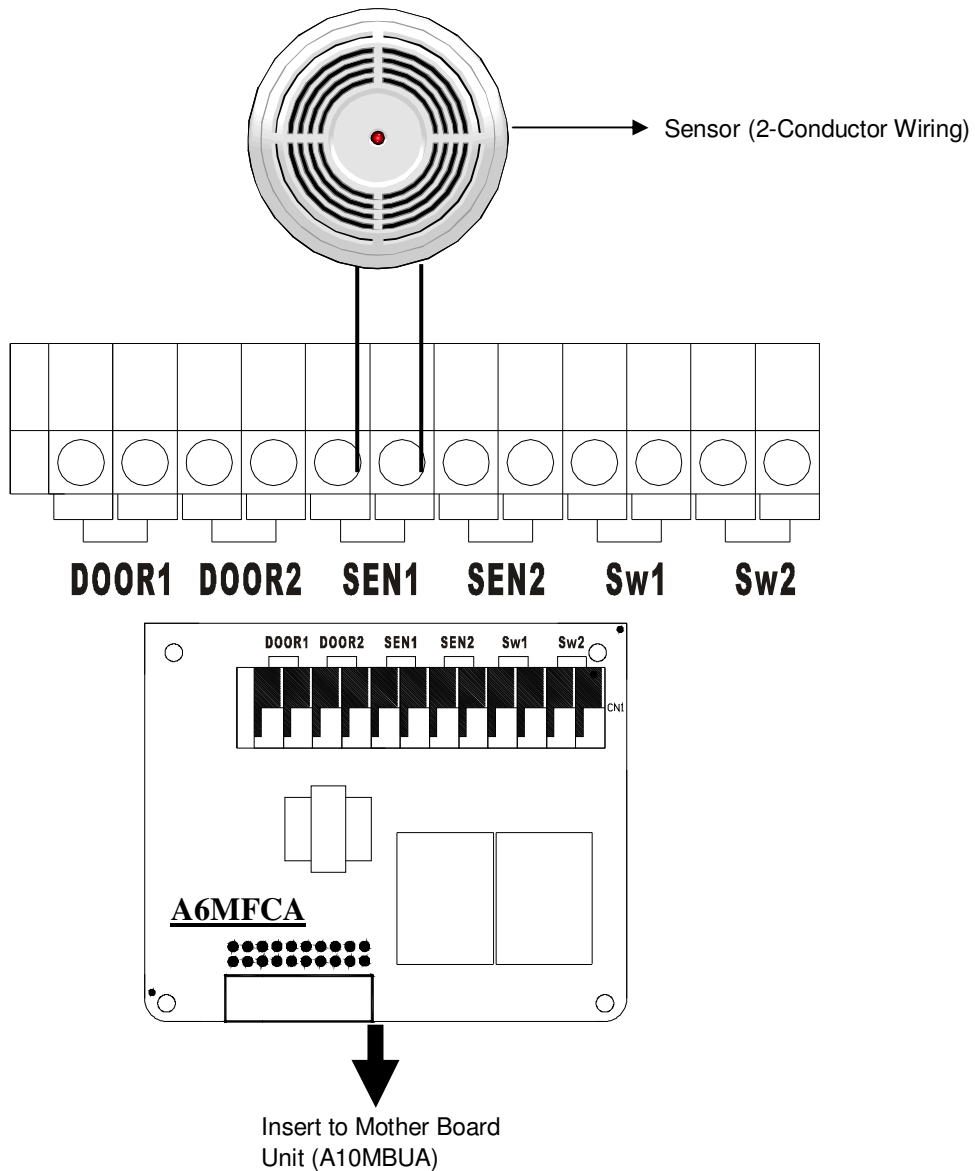
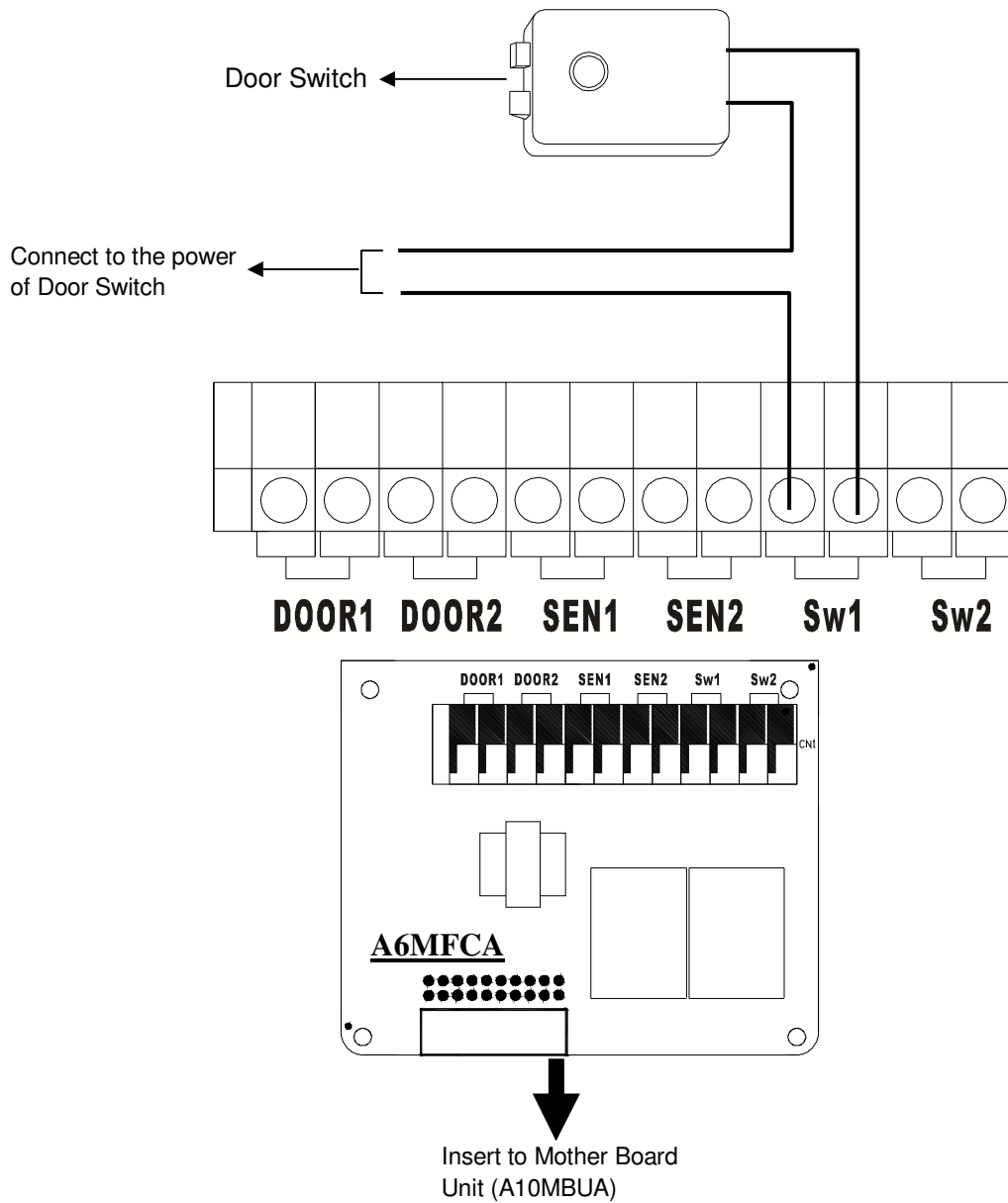

Chart 24: AV-48 Multi-function Relay—Door Switch Installation

- The application of the Relay can be changed by the system programming. Built-in 2-conductor wiring for this installation. For the details of wiring, please see above chart 24.
- This system offers two multi-function relay installation inputs (SW1, SW2), located on A6MFCA.
- Also refer to the System Program Zone 302.

5.10 AV-48 External Music Source Installation

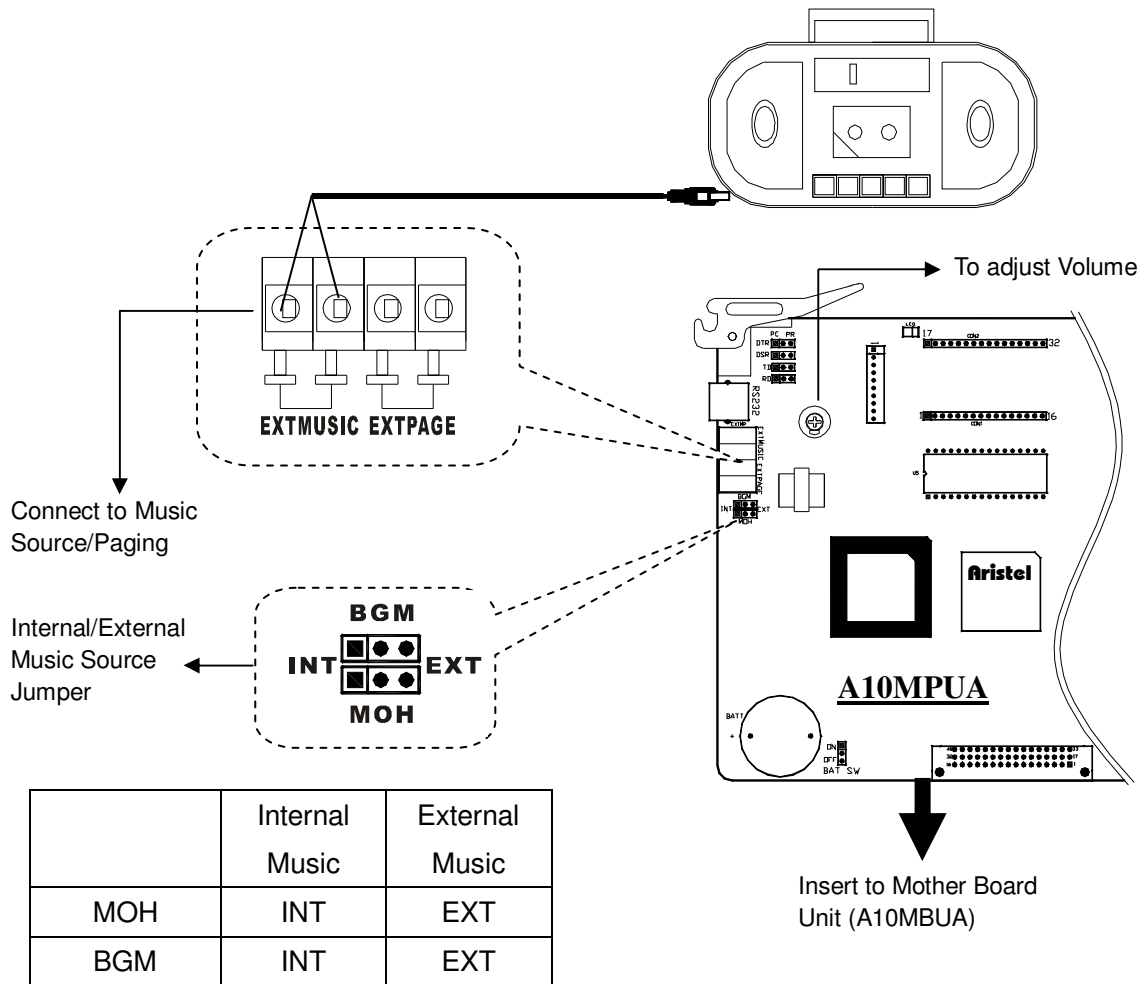

Chart 25: AV-48 External Music Source Installation

- External music source (Volume Adjustable) input is located on A10MPUA.
- The system offers a group of external music source input.
- When using external music source as MOH or BGM, Internal/External Music Source Jumper must be jumped correctly, as above chart 25.

5.11 AV-48 External Paging Installation

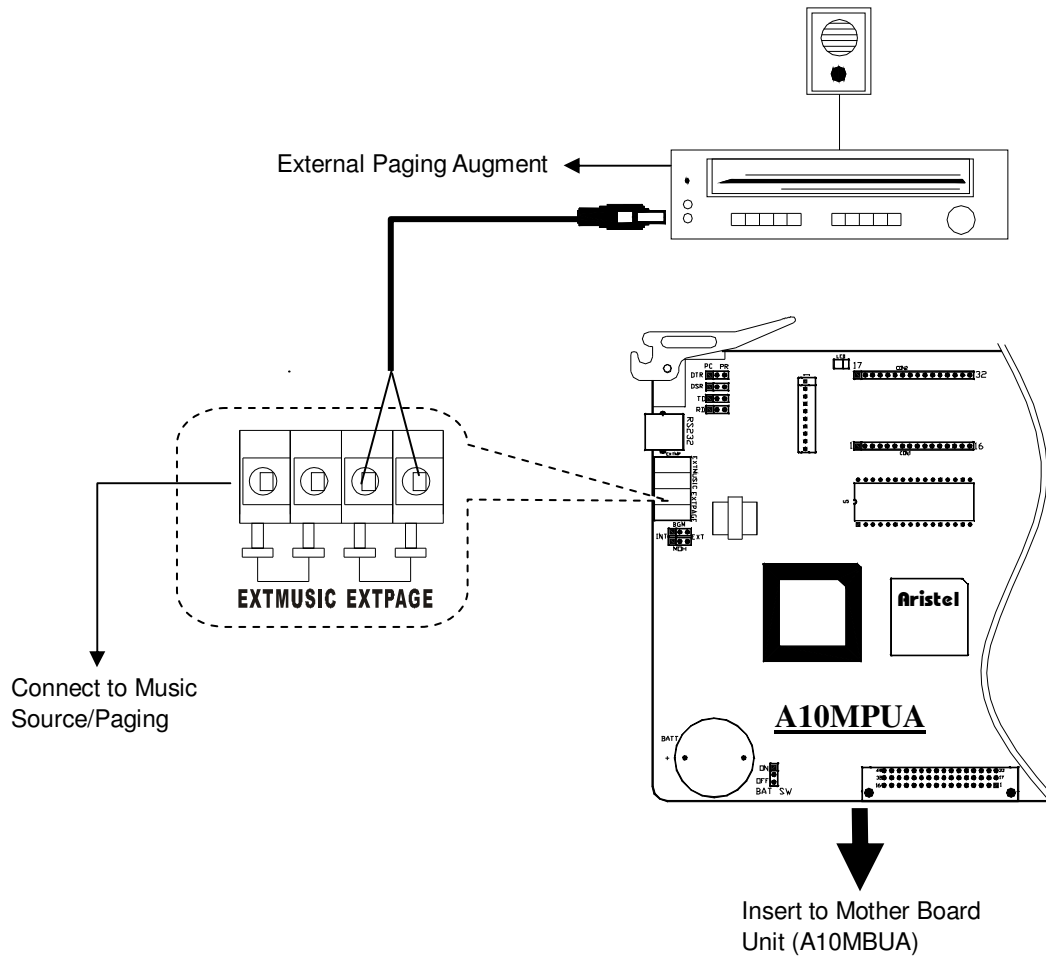

Chart 26: AV-48 External Paging Installation

- External paging input (EXT PAGE) is located on the A10MPUA.
- The system offers a group of external paging.
- 2-conductor wiring is used for external paging.

5.12 AV-48 RS232 (SMDR) Installation

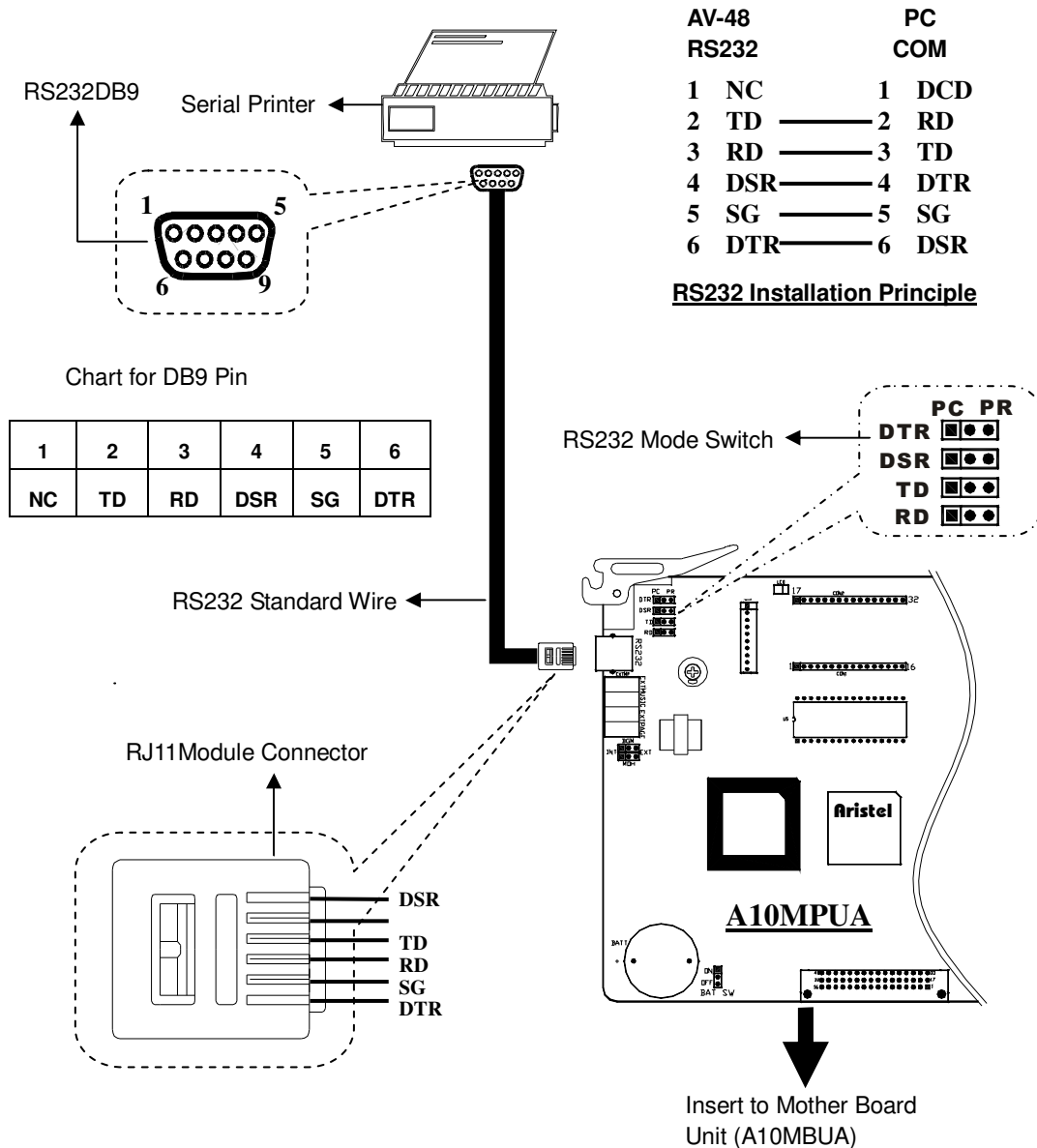

Chart 27: AV-48 RS232 (SMDR) Installation

- The system provides 1 RS-232 output outlet.
- RS-232 output port is located on A10MPUA, using a 6-conductor RJ11 connector.
- RS-232 port provides the functions of SMDR and PC-online system programming maintenance.
- When using RS232 and connecting the PC or Printer, RS232 mode switch must be jumped correctly as above chart 27.
- If the RS232 standard wire is not long enough, customers may extend it with notice of every core's corresponding.

Key Telephone System

AV-48

System Installation Manual

DOC : AV-48 System Installation Manual

Edition Version: 1.0

Editor : Sherry Wang

Date : 2005/09/01

